



## Testing of Explosibility and Flammability of Airborne Dust from Wood Pellets

Staffan Melin  
 Research Director  
 Wood Pellet Association of Canada  
 November 2, 2008

### 1. Introduction

This report is a summary of the findings from physical characterization and testing the explosibility and flammability of dust collected during handling of white pellets as well as bark pellets. Explosions and fires are quite common in the industry processing wood, including the wood pellet industry, as can be seen in the diagram on the right hand side illustrating the officially recorded incidents in USA. It is of interest to notice the relatively small rate of incidents in the coal mining industry which traditionally has had a reputation of having many serious incidents.

Figure 2: Ignition Sources of Dust Explosions

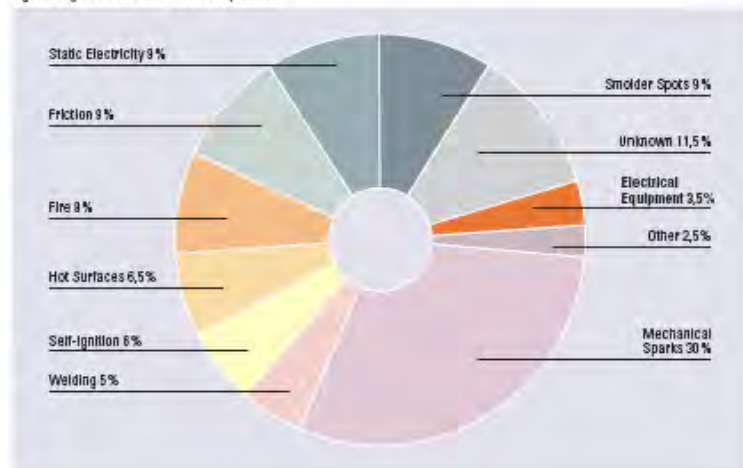

To better understand the significance of dust generated during handling, the report includes some rudimentary particle physics to give a perspective on the behavior of dust suspended in air since it is the basics of much of the procedures for testing explosibility.

(Courtesy R. Stahl  
 Schaltgeräte GmbH)

Figure 3: Types of Dusts Involved in Dust Explosions



## 2. Particulate Physics Orientation

Airborne dust from wood pellets is the cause of many fires and explosions when exposed to ignition source or heat and often results in substantial damage and injuries. Airborne dusts are part of the wide spectrum of aerosols and are classified in the following main categories with typical size range indicated in the diagram below;

- Combustion generated particles
- Mechanically generated particles
- Spores
- Bacteria
- Viruses

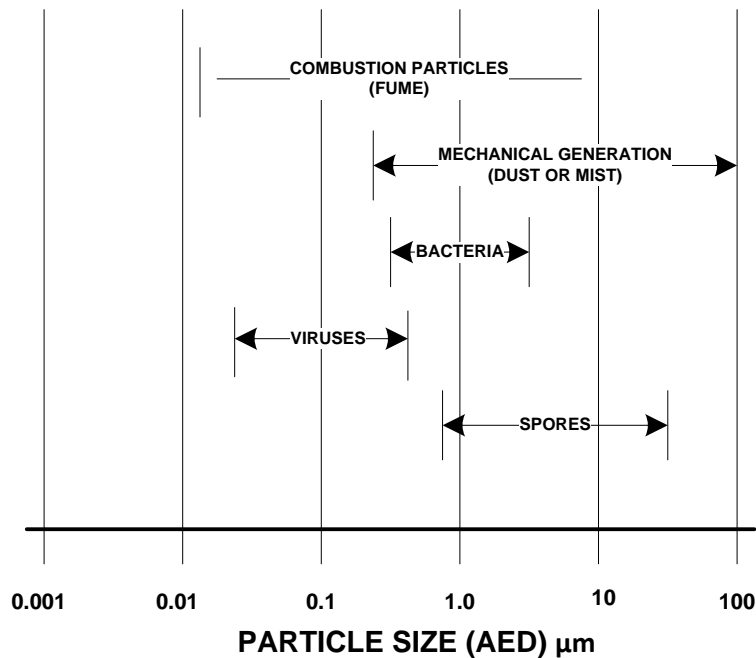

Particulates smaller than 425 μm (screen 40) are classified by OSHA as dust. To give a perspective on the size of particulates, cement dust range from 2-100 μm, diesel exhaust 0.001-1 μm and a human hair 20-180 μm. The actual size of particles is difficult to measure with any accuracy since they almost always appear in large numbers with individual shapes and sizes and each particle is almost always irregular in shape, often with porosity. The shape and size is often also affected by changes in moisture and temperature. In the industry the size is often determined by mechanical sieving with results affected by the geometry and duration of the vibrations of the sieving equipment. The result of mechanical sieving is often in question since the mesh through which the material is passing has no way of discriminating particles of different density and particles with non-spherical (ideal) shape or particles smaller than a certain diameter. Particles such as fibers with an aspect ratio larger than 1:5 are particularly difficult to classify by mechanical sieving.

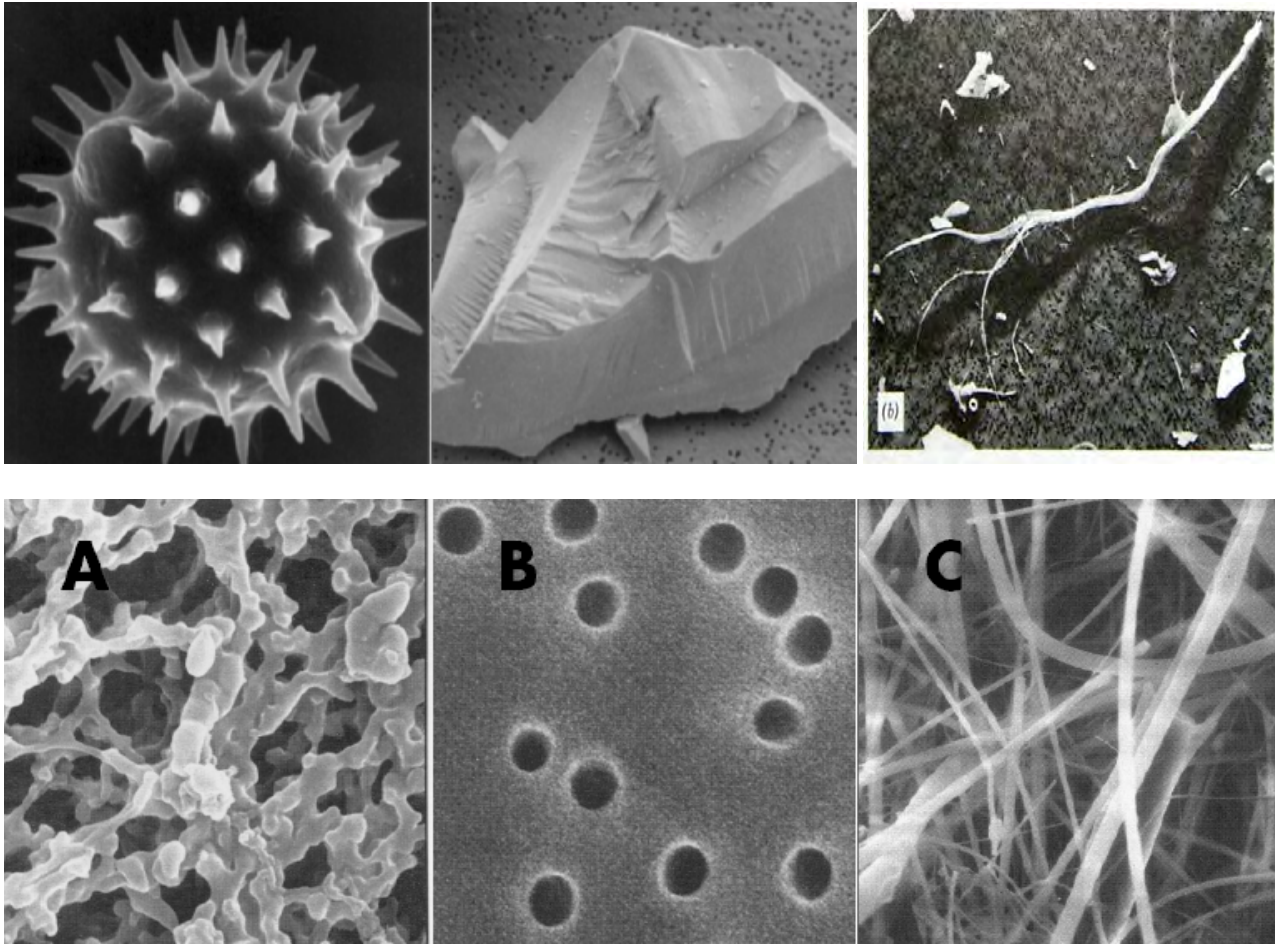

An alternative method of classifying particles is machine vision using a high resolution scanner and image processing software. Both methods are approximations although the machine vision should be considered more accurate.

Particles which are not in the sediment state are often in an agitated and lofted stage by the media in which they habitate. The agitation is due to external forces acting on the particles such as turbulence, buoyancy, fluid drag, static electricity, Brownian forces, Van der Waal forces and gravity. The dynamics of how particles propagate in a media, such as air, is of fundamental importance in dust control. Practically all particles are non-uniform in shape and have different density depending on material and porosity and therefore are transported at different speed in air due to the forces of gravity, buoyancy and fluid drag forces as illustrated to the right.

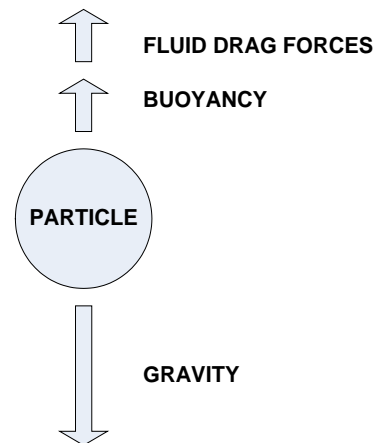

Some of the critical factors with all aerosols is the concentration in any given area and the speed at which concentrations may occur. An understanding of the net effect of the forces

exerted on the particle is essential and is quantified in terms of sedimentation (settling) speed of the particles under still as well as turbulent conditions. The sedimentation speed is primarily affected by the physical size, surface structure and density of the particle. The concept of **Aerodynamic Equivalent Diameter (AED)** is a way to relate the particle characteristics to the sedimentation speed at normal temperature and atmospheric pressure (NTP). One method is based on a determination of the projected area of the particle and the other is based on the volumetric determination of the particle, both normalized to an equivalent droplet of water with density  $1,000 \text{ kg/m}^3$ . The two methods results in an (AED). The sedimentation speed is then calculated using Stokes formula.

The two methods are illustrated below with parametric values to arrive at the same sedimentation speed.

### THREE METHODS OF ESTIMATING PARTICLE DIAMETER BASED ON SEDIMENTATION SPEED

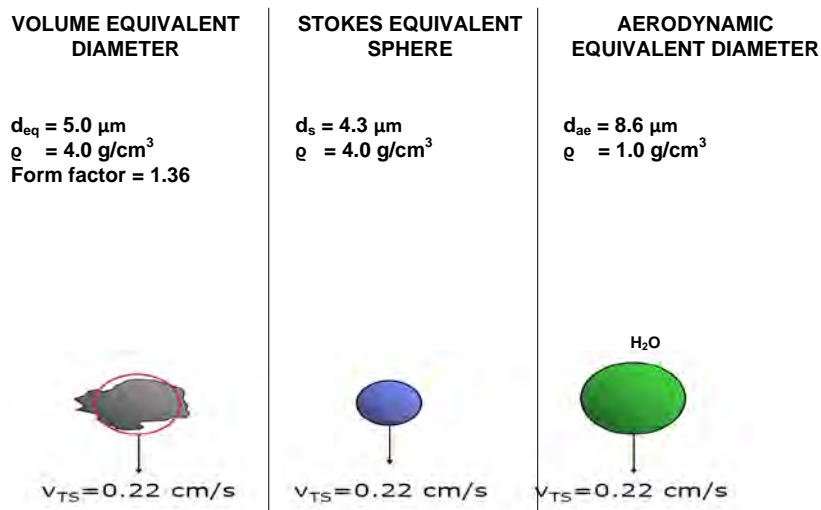

In turbulent air particles remain airborne for a longer period of time, particularly smaller particles. The sedimentation time has a direct impact on the concentration of particles in a given containment as well as the time it takes to build up a sediment layer. In still air larger particles settle much quicker than smaller particles as illustrated in the figure below.

## PARTICLE SEDIMENTATION TIME IN STILL AIR

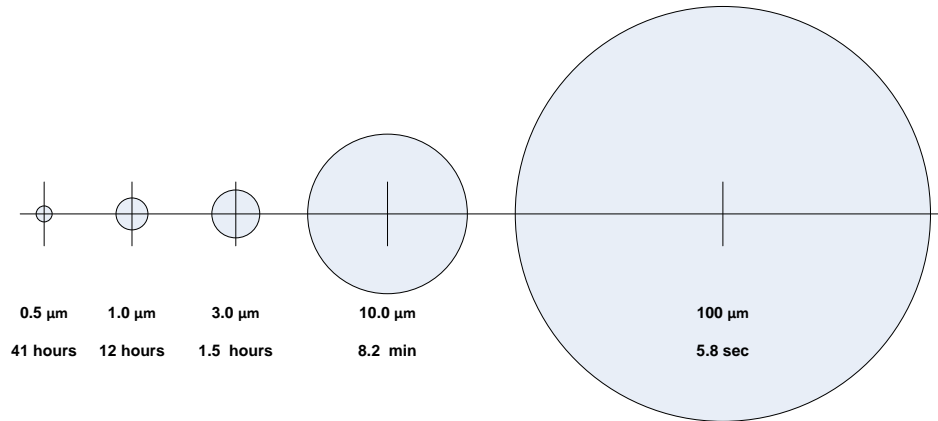

TIME TO SETTLE 5 FEET BY UNIT DENSITY SPHERES

Source: NIOSH

The airborne dust generated during handling of pellets range in size from 500 to a few micron (see section on Samples below). The above figure indicates a sedimentation (settling) time from a few seconds to several hours in still air. The time is even longer in turbulent air.

The smaller the particle is the larger the relative surface area, which means increased exposure to the oxygen in the air. The larger the oxygen exposure is of combustible material the higher the risk is for open flame combustion in the presence of an igniting source or a source of heat.

Aside from the safety and infectious aspect of some particles we are also concerned with **health effects** from exposure to particles with an AED less than 100 µm. Depending on size, aerosol particles easily deposit in various parts of our airways as we inhale and subsequently causes illnesses such as acute reactions, chronicle reactions or tumors. The most serious damage is done by particles less than 10 µm AED which are able to enter our bloodstream through the alveolars where the gas exchange (oxygen uptake) takes place in our lungs. The medical field is using the following classifications for particles with penetration illustrated in the figure below;

- Inhalable particulates < 100 µm AED
- Thoracic particulates < 25 µm AED
- Respirable particulates < 10 µm AED

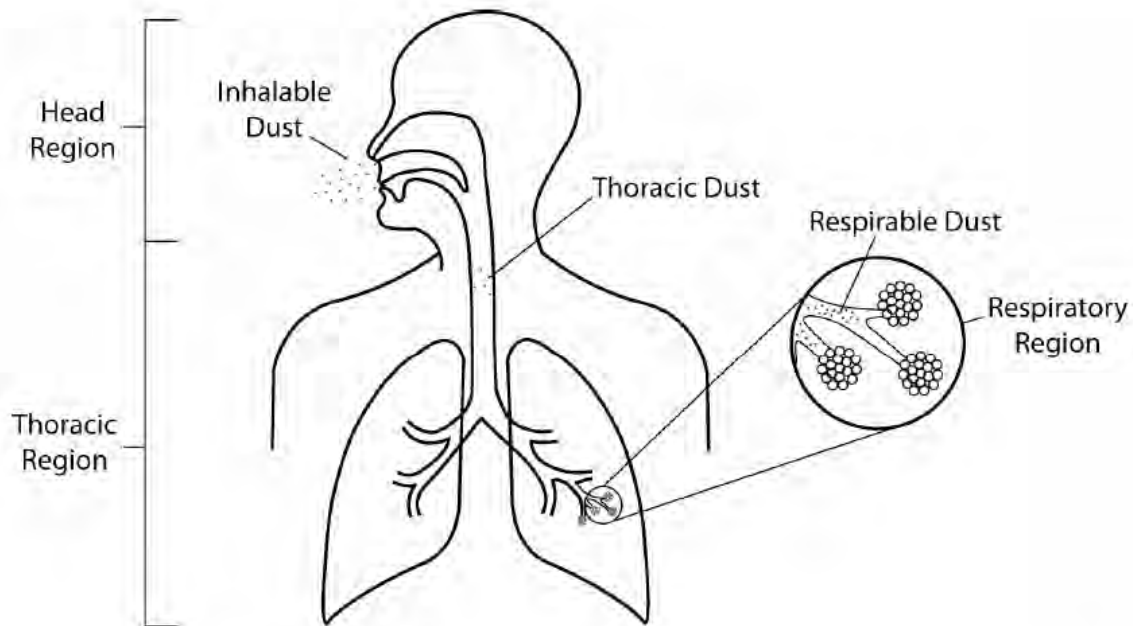

Adapted from Annals of American Conference of Governmental Hygienists, Vol. 11

### **Regional Particle Deposition in the Airways**

As a curiosum, it is estimated that during a lifetime an average person is inhaling over  $10 \text{ m}^3$  of air per 24 hours which translates in to about  $4,000 \text{ m}^3$  per year or  $320,000 \text{ m}^3$  during an 80 year lifespan. A typical outdoor particle concentration is about  $3 \mu\text{g}/\text{m}^3$  inhaled. This translates in to about 3 g of particulates inhaled during a lifetime, which is about 3 teaspoons full of particles<sup>1</sup>. The surface of the head region exposed to air is about  $0.5 \text{ m}^2$ , the bronchial-thoracic region about  $2 \text{ m}^2$  and the respiratory alveoli region about  $100 \text{ m}^2$ .

### **3. Dust Samples Tested**

Samples of dust from wood pellets used in the testing of explosibility and flammability in this report were collected in areas where the dust had settled which means that the particles were representative of the entire spectrum of sizes encountered in a typical working environment for bulk handling of pellets. The particles had been airborne and transported a distance before settling and therefore can be classified as passing through a band pass filter. Sample A from white pellets was collected at a downstream transfer point between conveyors at a shiploading terminal. Sample B from bark pellets was collected at girts, ledges and bin tops on the production floor inside a pellet mill. No grinding or hammer milling of the material was done after sampling. The samples were kept in sealed plastic bags until opened at the lab immediately before testing.

The particle size spectrum for the two samples was established by means of wire cloth sieving as well as by use of a new machine vision system developed at University of British Columbia. The result of the size determination is shown in diagram below. For comparison,

<sup>1</sup> Partiklar och Hälsa, Gudmundsson, 2008.

the diagram is also including typical particle size distribution for Pittsburgh coal and Lycopodium spores.

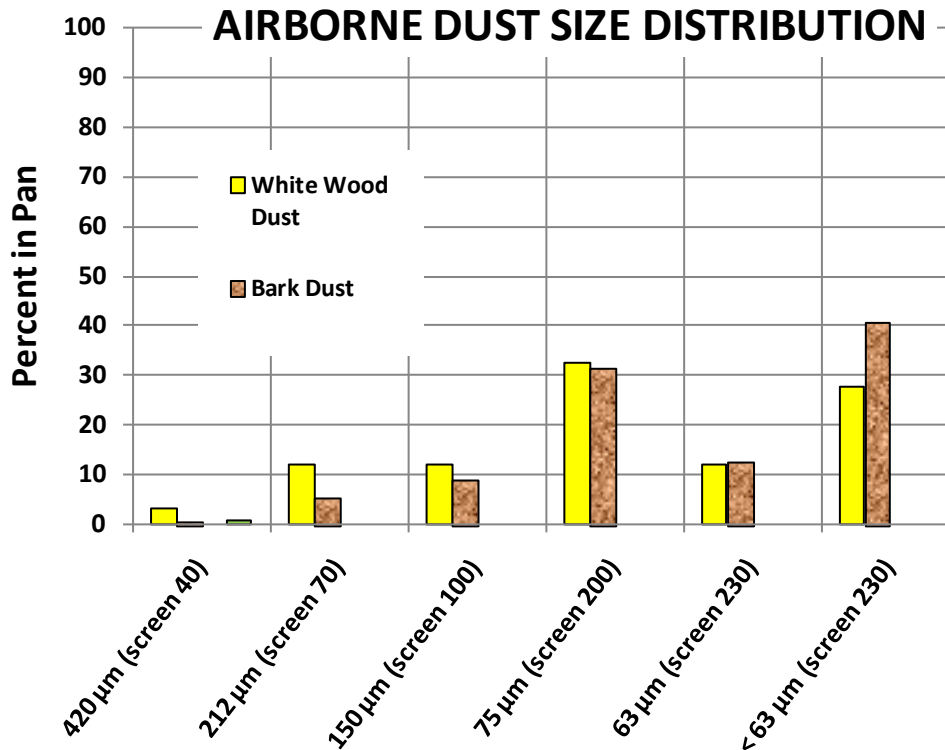

The Lycopodium spores are often used as a reference since the spores have very predictable and consistent particle size of 20-30 μm and is naturally suspended in air (see picture to the right). The spore also has a large surface area and therefore has a high level of explosivity.

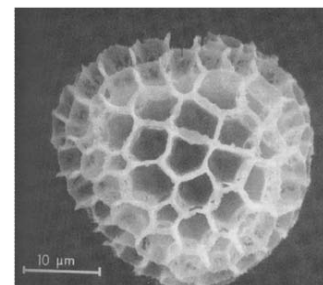

In comparison, the dust generated during coal mining operations varies from 1 to 200 μm depending on the mineral composition and the mining process. The particle size distribution is very similar to the dust from wood pellets.

For this report the ASTM Standards have been followed. Similar testing standards are also published under ISO, EN and some national standards in Europe. The tests have been performed on screen 230 materials (particles 63 μm or less) since over 80 % of the dust particles are 75 μm or less and about 50 % or more is 63 μm or less. Based on the size distribution the most representative particle size would be somewhere between screen 200 and 230 (see diagram above). The ISO Standards recommend 63 μm as the norm for testing purposes.



#### 4. Explosibility

Explosion is used as a general characterization of a violent event emitting sound and light and often immediately followed by fire. There are two main categories of explosions. **Detonation** generated from a sudden expansion of gas in to a supersonic shock wave (molecular speed is higher than the speed of sound). An example is nuclear explosions such Castle Romeo 2 nuclear test 1954 (to the right). The other is **deflagration** generated by an initial violent oxidation followed by a frontal combustion propagating outward as long as fuel and oxygen is present in sufficiently high concentrations (see deflagration flame supported by fuel to the right).



Explosions occur in dust suspended in air as well as dust sediments on hot surfaces. The explosibility is a function of particle concentration, oxygen concentration, energy of the ignition source or the temperature of the heat exerted on the dust. In order to emulate real live conditions as close as possible a number of Testing Standards are available. The following table summarizes the results of the tests which have been conducted on dust from white pellets as well as bark pellets.



Standards tests are conducted on **Dust Clouds** as well as **Dust Layers**. The result of the tests generates a **Dust Classification** which is used as a guideline for how the product generating the dust should be handled and how the handling facility should be designed.

Table 4.0 Results from testing dust from white pellets and bark pellets								
Test Mode	Test Parameter (dust <63 μm)		Measure	White Dust	Bark Dust	Coal Dust	Lycopodium Spores	Testing Standards
Dust cloud	Auto-ignition Temp (Godbert-Greenwald)	T <sub>c</sub>	°C	450	450	585	430	ASTM E1491
	Min Ignition Energy	MIE	mJoule	17	17	110	17	ASTM E2019
	Max Explosion Pressure	P <sub>max</sub>	bar	8.1	8.4	7.3	7.4	ASTM E1226
	Max Explosion Pressure Rate	dP/dt <sub>max</sub>	bar/sec	537	595	426	511	ASTM E1226
	Deflagration Index	K <sub>St</sub>	bar.m/sec	146	162	124	139	ASTM E1226
	Min Explosible Concentration	MEC	g/m <sup>3</sup>	70	70	65	30	ASTM E1515
	Limiting Oxygen Concentration	LOC	%	10.5	10.5	12.5	14	ASTM E1515 mod
Dust Layer	Hot Surface Ignition Temp (5 mm)	T <sub>s</sub>	°C	300	310			ASTM E2021
	Hot Surface Ignition Temp (19 mm)	T <sub>s</sub>	°C	260	250			ASTM E2021
	Auto-ignition Temp	T <sub>L</sub>	°C	225	215			USBM (Bureau of Mines) RI 5624
Dust Class (>0 to 200 bar.m/sec)				St 1	St 1	St 1	St 1	ASTM E1226
Dust Class (Explosion Severity (ES > 0.5)				Class II	Class II			OSHA CPL 03-00-06

The smaller the particle is the higher the explosibility. The bark dust contains noticeably higher percentage smaller particles compared to the white dust. This translates in to higher explosion pressure.

The minimum explosivity concentration (MEC) for coal dust is practically the same as for dust from wood pellets. Coal dust explosions can be mitigated partly by injection of



incombustible mineral dust (e.g. limestone) at air intakes in order to keep the dust concentration below the critical  $65 \text{ g/m}^3$  level of coal dust. This option is not practical for operations handling wood pellets.

The following sections describe each test in principle. These methods were used in 2008 for testing dust from pellets manufactured in British Columbia and Nova Scotia in August 2008. The results are the basis for the data documented in the MSDS. For more information, see the actual Standards and the related reference documentation. It should be noted that the data obtained from the testing as outlined in the Standards is not necessarily intrinsic to the tested material but may be used for assessing the risk for explosions and fires together with local conditions and sizing of explosion vents.

The moisture of the samples to be tested shall not exceed 5 % in order to avoid a substantial influence from the moisture on the results.

#### **4.1 Minimum Auto-Ignition Temperature in Dust Cloud - $T_C$ (ASTM E1491-06)**

The general principle of this testing is to have dust dispersed into a cloud and expose the cloud to radiated heat. The minimum auto-ignition temperature is defined as the temperature at which the cloud ignites. The detailed requirement to achieve reproducible results is found in the ASTM E1491 Standard. There are several apparatuses recommended in the Standard as illustrated below (courtesy ASTM E1491-06 Standard).

The Godbert-Greenwald apparatus (see schematic to the right) was used for the testing of material from British Columbia and Nova Scotia in August 2008. The Pyrex tube has a volume of 0.27 Liter (diameter 3.8 cm and length 30.5 cm) and is fed from the top with a predetermined amount of dust cascading down, injected by an air burst from the exit at the bottom is an

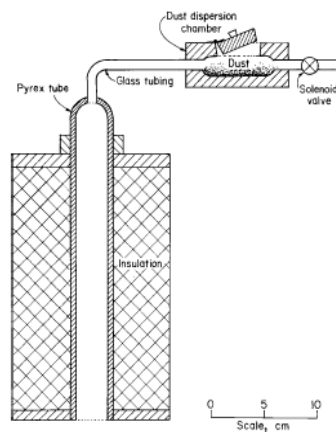

top. A flame observed at the indication of ignition. The

furnace temperature is measured with type N thermocouples.

The apparatus on the right called BAM is defined by Bundesanstalt für Materialforschung und Prüfung. A predetermined amount of dust is fed horizontally into the oven from the right and dispersed by the deflection surface inside the oven with the flame exiting on the left hand side upon ignition.

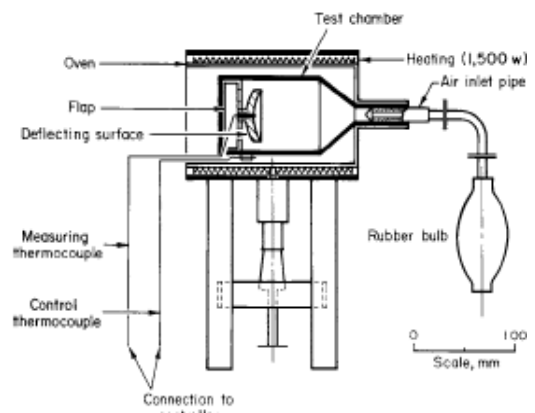

The apparatus on the right is defined by the US Bureau of Mines with a volume of 1.2 Liter is fed from the bottom. When the dust ignites the burst diaphragm at the top will break and a flame will appear at the top.

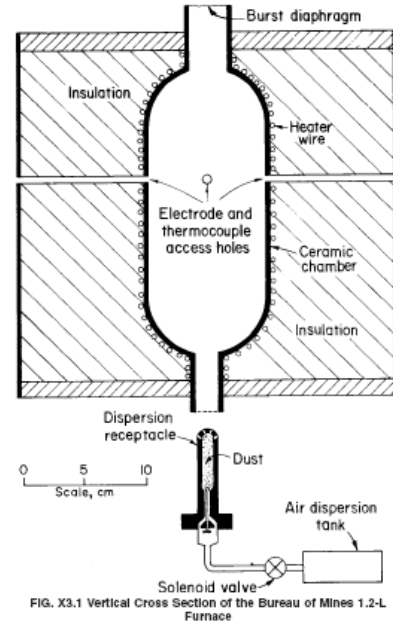

The different methods produce results within  $\pm 5\%$  with an increasing variance for materials with higher minimum temperature. A typical result from testing a material is illustrated in the graph to the right. Obviously, the concentration of particulates in the cloud is an important variable.

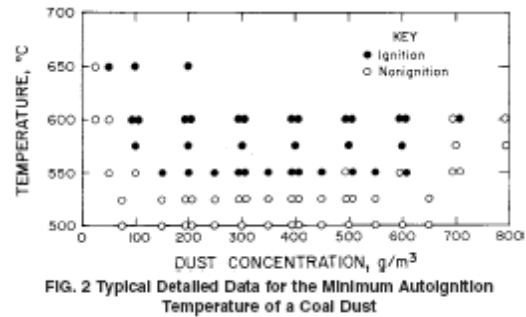

#### 4.1 Minimum Ignition Energy in Dust Cloud – MIE (ASTM E2019-03)

The general principle with this test is to estimate the energy required to ignite a dust cloud by means of an electrical discharge. Since the ignition of the dust is dependent on the concentration of the dust, dust-air turbulence and the discharge energy the test is iterative to find the least concentration in combination with the least energy in the discharge spark. A typical apparatus consists of a chamber, spark electrodes and a spark generation circuit. The idea is to create a non-turbulent dust-air mixture with a known dust concentration by means of a delayed discharge after the dust has been injected into the chamber from the bottom. A 1.2 or 0.5 Liter Hartmann tube may be used as a chamber. The spark gap shall be 2-6 mm and a gap resistance of  $10^{12} \Omega$  is required for a minimum ignition energy (MIE) of 1 mJ and  $10^{10} \Omega$  for an MIE of 100 mJ and the discharge voltage is several thousand volts (see ASTM Standard for further details). The apparatus discussed in Section 4.2 may also be used for this test.



(Courtesy Adolf Kühner AG) (Courtesy Physikalische-Technische Bundesanstalt PTB)

Electrostatic discharge from person to a metal surface during summertime is typically 20 mJ and about 60-80 mJ during wintertime when the humidity in the surrounding air is lower.

The relation between product moisture and MIE is illustrated in the diagram on the right hand side.

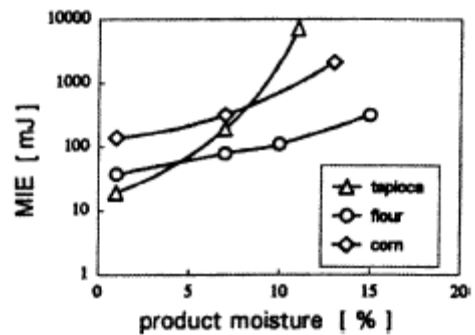
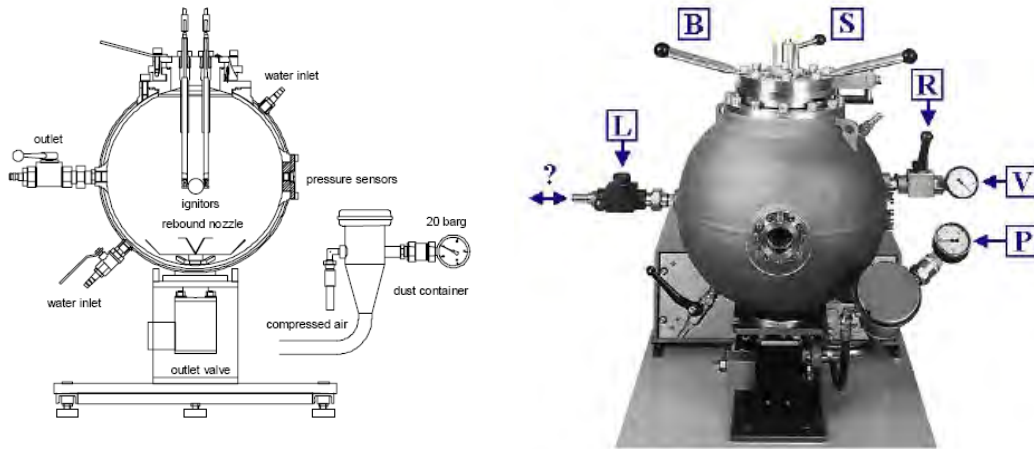

FIG. 2 Influence of the Humidity (Water Content) of Combustible Dusts (5)

#### **4.2 Maximum Explosion Pressure ( $P_{max}$ ), Pressure Rate ( $dP/dt_{max}$ ) and Deflagration Index ( $K_{st}$ ) in Dust Cloud – (ASTM E1226-05)**

The general principle is to test the severity of explosions in a dust-air mixture in a closed spherical chamber with a volume of 20 Liter. The maximum pressure and the maximum rate of pressure rise are measured. The most common apparatus used is the spherical 20 Liter Siwek explosion chamber as depicted below.



(Courtesy Adolf Kühner AG)

The Pressure is measured in bar (usually called bar-g meaning gauge reading) and designated  $P_{max}$ , the Pressure Rate in bar/second  $dP/dt_{max}$  and the Deflagration Index  $K_{St}$  in bar.m/s measured at maximum dust concentration. The  $K_{St}$  is extracted from the following formula normalized to 1.0 m<sup>3</sup>:

$$K_{St} = (dP/dt)_{max} V^{1/3}$$

- where  $P$  is pressure in bar
- $t$  is time in seconds
- $V$  is Volume in m<sup>3</sup>
- $K_{St}$  is bar meter per second

The results of the testing is very much dependent upon the concentration of dust, particle size, turbulence in the chamber, geometry of the vessel, energy dissipated by the ignition source, homogeneity of the air/dust mixture, initial pressure and initial temperature. The following diagrams illustrate typical recordings of explosions with the single explosion data on the left hand side and the iterative data on the right hand side as a function of dust concentration.

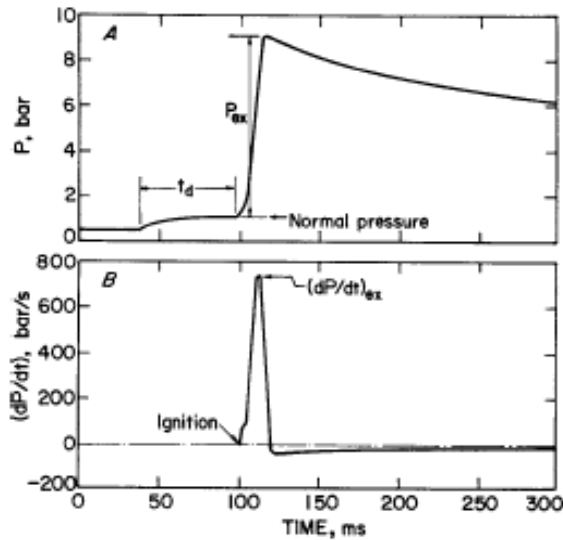

FIG. 1 Typical Recorder Tracings of Absolute Pressure,  $P$ , and Rate of Pressure Rise,  $dP/dt$ , for a Dust Deflagration in a 20-L Chamber

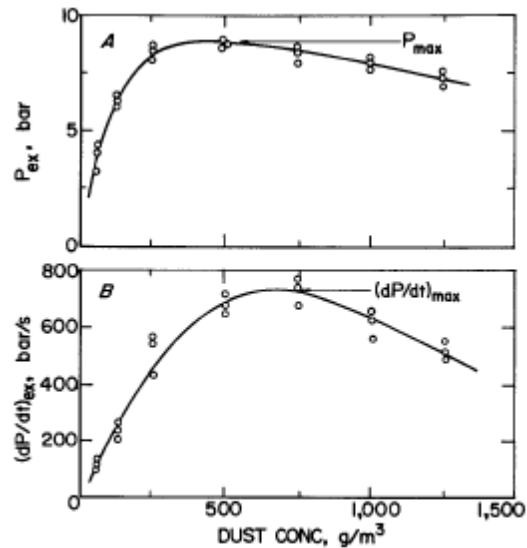

FIG. 2  $P_{max}$  and  $(dP/dt)_{max}$  as a Function of Concentration for a Typical Dust in a 20-L Chamber

(Courtesy ASTM E1226-05 Standard)

In case of mild deflagration of less than 150 bar/s the pressure curve for the ignitor may impact the interpretation of the result. As an example, with an ignitor energy of 10,000 J the pressure tangent for the dust under test may be drawn after 50 ms to minimize the effect of the ignitor as illustrated in the diagram below (Courtesy ASTM E1226-05 Standard).

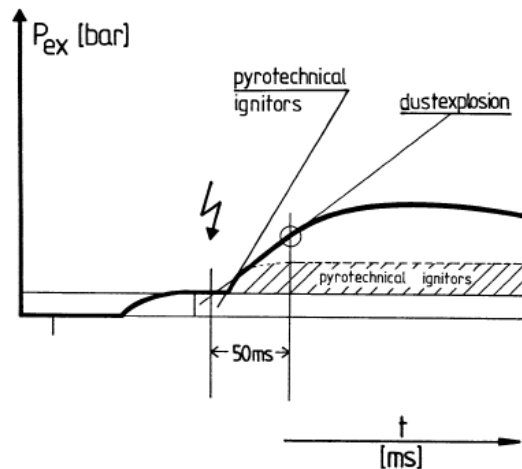

FIG. X1.7 Mild Dust Explosion

The  $K_{St}$  is the basis for Dust Explosibility Classification in the following three ranges;

Dust Explosibility Class	$K_{max}$ [ bar.m/s ]
St 1	>0 - 200
St 2	201 - 300
St 3	>300

The value obtained from the Siwek apparatus is normalized to 1 m<sup>3</sup> by using a formula in order to be compatible with the nomograms in NFPA 68 Standard for sizing of deflagration vents. The calibration of the values between the ISO chamber and the Siwek chamber are made by means of explosibility of certain well known compounds such as Lycopodium Spores and Pittsburgh Seam Bituminous Coal Dust with a maximum variance of ± 20 %.

In case the deflagration is difficult to achieve in a 20 Liter chamber using a 5,000 or a 10,000 J ignitor, it is recommended that a 1 m<sup>3</sup> chamber is used as specified in the ISO 6184/1 Standard using a 10,000 J ignitor.

### **4.3 Minimum Explosible Concentration in Dust Cloud – MEC (ASTM E1515-07)**

The Minimum Explosible Concentration (MEC) is also referred to as Lower Explosibility Limit (LEL) or Lean Flammability Limit (LFL). Data from this test provides a relative measure of the minimum concentration of well dispersed dust capable of propagating a deflagration. The Siwek apparatus as described in Section 4.2 is used for the MEC testing. A less common alternative is a chamber specified by US Bureau of Mines may be used as illustrated below.

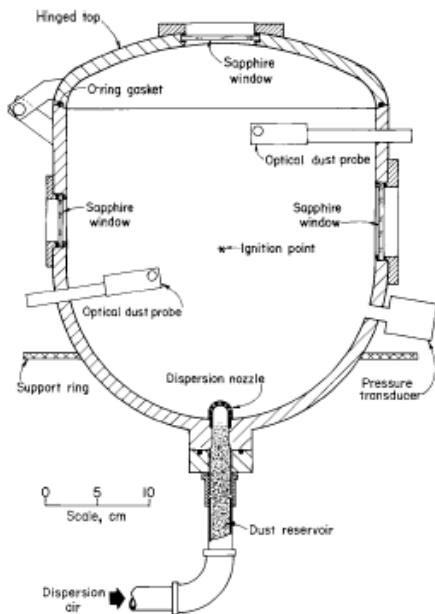

FIG. X1.1 Vertical Cross Section of Bureau of Mines 20-L Chamber

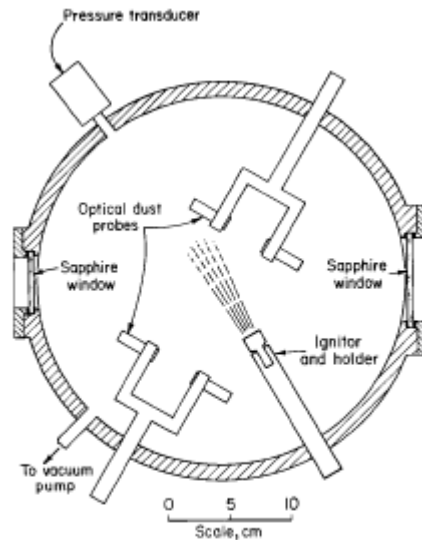

FIG. X1.2 Horizontal Cross Section of Bureau of Mines 20-L Chamber

(Courtesy ASTM E1515-07 Standard)

Attention has to be given when dust with low explosibility limit is tested to make sure the pressure from the ignitor is not confused with the pressure generated by the dust explosion. The following diagrams illustrate the pressure recording for a weak and a moderate dust deflagration.



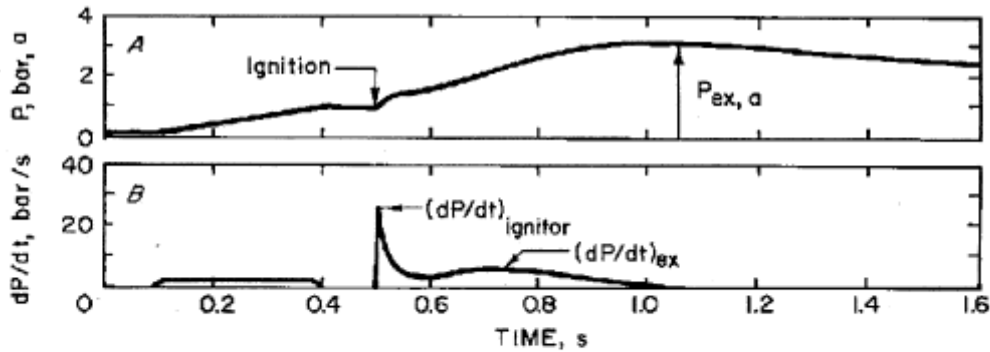

FIG. 1 Typical Recorder Tracings for a Weak Dust Deflagration in a 20-L Chamber, using a 2500 J Ignitor

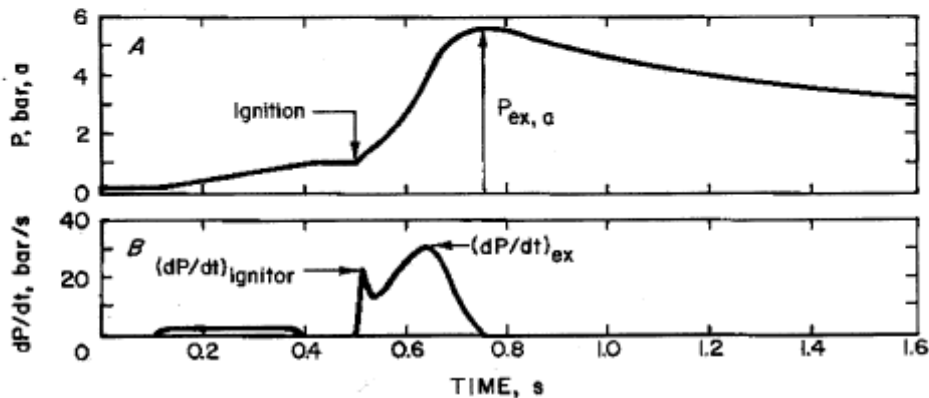

FIG. 2 Typical Recorder Tracings for a Moderate Dust Deflagration in a 20-L Chamber, using a 2500 J Ignitor

#### **4.4 Limiting Oxygen Concentration in Dust Cloud – LOC (ASTM E1515 mod.)**

The general principle of this test is similar to the MEC described above using the same equipment with a slight modification to the procedure of operating the unit. The oxygen concentration in the chamber is successively adjusted by injection of nitrogen and the pressure prior to injection of dust is lowered to -0.6 bar. The pneumatic injection of dust brings the pressure up to 1 bar followed by the ignition. The lowest value of oxygen is reached close to the lowest cloud density.

#### **4.5 Hot Surface Ignition Temperature of Dust Layers – $T_s$ (ASTM E2021-06)**

The general principle for this test is to establish the temperature at which a layer of dust with a certain thickness will ignite or self-heat when residing on a hot surface. The test is conducted by placing a ring of metal with a diameter of 100 mm and a certain depth on a hot plate and the ring is filled with dust. The temperature of the hot plate is set at different temperatures and the temperature within the dust layer is measured with a thermo-couple. The depth of the ring may be selected to mimic realistic thicknesses found in the area of concern in a location where dust accumulates. In the case of the testing reported in this document a ring with a depth of 5 and 19 mm respectively were used. The test setup is depicted below.

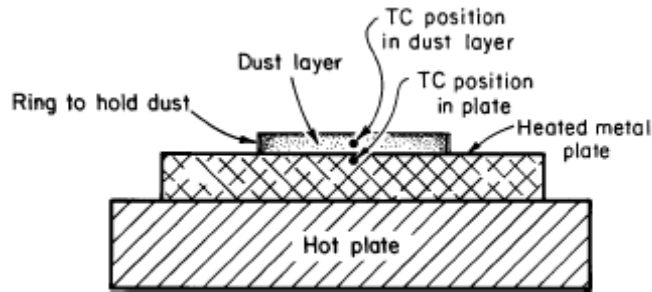

FIG. 1 Schematic of Hotplate Layer Ignition Apparatus

(Courtesy ASTM E2021-06 Standard)



Ignition is deemed to have occurred if within a 60 minute period the sample temperature rises to 50 °C, or more above the hot plate temperature, or a red glow or a flame is observed in the sample. The following diagram illustrates the definition of ignition at +290 °C but not at +280 °C.

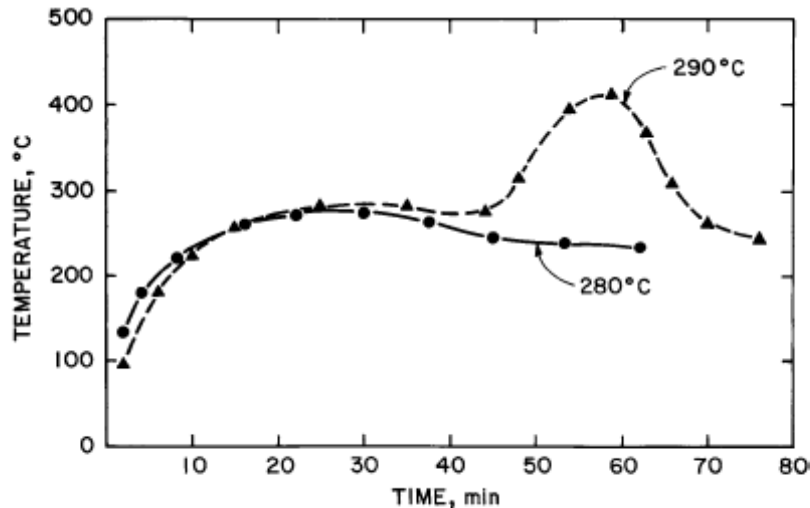

FIG. 4 Test Data Showing Nonignition at Set Temperature of 280°C and Ignition at Set Temperature of 290°C

(Courtesy ASTM E2021-06 Standard)

The ignition temperature for other thickness of dust layers can be estimated using extrapolation or interpolation based on a minimum of two experimental numbers using a linear relationship within a certain constraint.

This method of measuring the ignition temperature is assuming no or very little movement of air in the immediate vicinity of the sample. The method outlined in Section 4.6 on the other hand is based on a steady flow of air in the space immediately surrounding the sample.

#### **4.6 Auto-ignition Temperature in Dust Layer – $T_L$ (Bureau of Mines RI 5624)**

The general principle for this test is to establish the temperature at which a layer of dust with a certain thickness will ignite or self-heat when residing on a hot surface. The test is conducted

by placing a sample basket (2.54 cm in diameter) in the center of a vertical tube furnace with a diameter of 3.6 cm and a length of 22.9 cm as illustrated below.

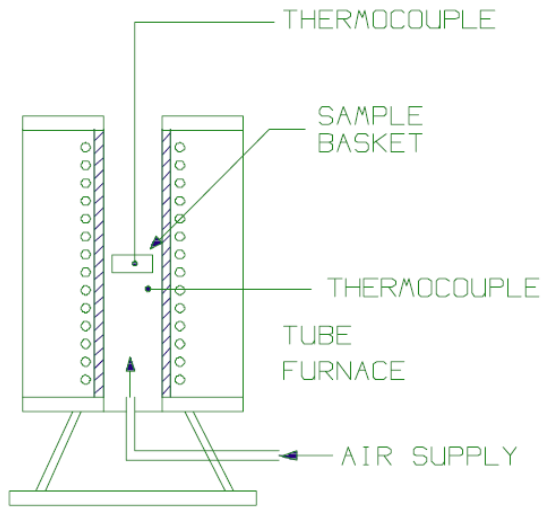

(Courtesy Kidde-Fenwal)

The furnace temperature as well as the sample temperatures are measured by thermo-couples and a steady flow of air at a rate of 1.3 Standard Liter per minute is fed from below to make sure the sample has sufficient supply of oxygen at all times.

This method is less accurate than the method presented in Section 4.5. The minimum ignition temperature is considered reached if the sample temperature reaches 25 °C above the temperature of the furnace within 5 minutes, or 50 °C without time restriction. The reporting criteria for Auto-ignition Temperature is defined as follows;

The minimum ignition temperature of a dust layer is the temperature which causes ignition after approximately 5 minutes (25 °C above furnace temperature) or, the average of the lowest temperature which causes ignition in less than 30 minutes and the highest temperature which fails to cause ignition in 30 minutes.

#### **4.7 Safety Classification – (29 CFR 1910.307)**

The US Code of Federal Regulations 29 CFR 1910.307 stipulate certain standards for equipment located in locations where hazardous dusts are present under normal operating conditions. The US National Fire Prevention Association guidelines NFPA 70 *National Electrical Code* defines the conditions in more detail. The US National Materials Advisory Board NMAB 353-3-80 *Classification of Combustible Dusts in Accordance with the National Electrical Code* defines dusts having Ignition Sensitivity (IS) greater than or equal to 0.2, or Explosion Severity (ES) greater than or equal to 0.5 to be appreciable explosion hazards requiring electrical equipment suitable for Class II locations.

$$\text{Explosion Severity (ES)} = \frac{(P_{max} \times R_{max})_2}{(P_{max} \times R_{max})_1}$$

where

- subscript 1 refers to Pittsburgh seam bituminous coal dust (3,110 bar<sup>2</sup>/s)
- subscript 2 refers to the dust under evaluation

The data obtained from testing dust cloud from white pellets manufactured in BC and dust from bark pellets manufactured in Nova Scotia forming the base for Table 4.0 is summarized in the following Table 4.7.

<b>Parameter</b>	<b>Measure</b>	<b>White Pellets Dust</b>	<b>Bark Pellets Dust</b>
P <sub>max</sub>	bar - g	8.1	8.4
R <sub>max</sub>	bar/s	537	595
P <sub>max</sub> x R <sub>max</sub>	bar <sup>2</sup> /s	4,350	4,998
ES		1.40	1.61
Dust Classification		Class II combustible	Class II combustible

Dust Classification Criteria according to the OSHA Directive CPL 03-00-06 is defined as follows;

<b>Test Results</b>	<b>Dust Classification</b>
ES > 0.5	Class II combustible
ES < 0.4	Not Class II combustible
0.4 < ES < 0.5	Combustible but not Class II
P <sub>max</sub> < 1 bar	Not combustible

Concluding from the test data, installations exposed to the white pellet dust as well as the bark pellet dust require equipment classified as Class II compatible. In daily language, such dust is often called Class II dust although the classification refers to the equipment.

#### **5. Flammability (UN Test N.1 – Class 4 Division 4.1 Substances)**

The objective of the test is to establish if the material under test shall be classified as flammable or not under the criteria stipulated by the Standard. A material burning a distance of 200 mm in 2 minutes or less, is classified as flammable. The flammability or burning rate of dust is investigated using an elongated mould 250 mm long with a triangular cross section with an inner height of 10 mm and width of 20 mm as depicted in the schematic below.

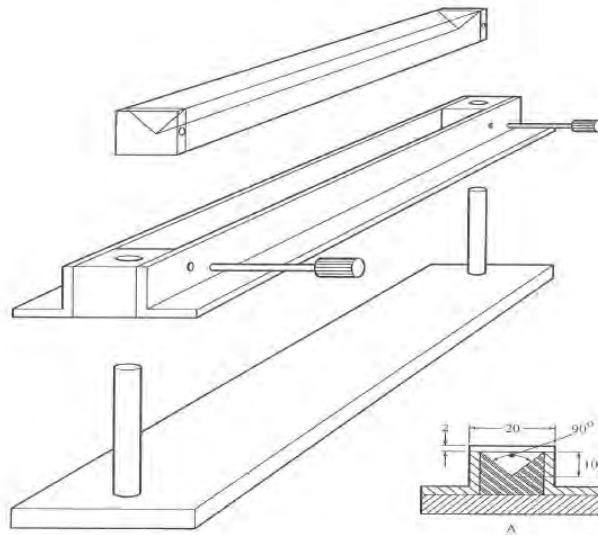

(Courtesy UN Manual of Tests and Criteria, rev. 3, 2000)

The mould is loosely filled with dust and the top of the mould is leveled off by a ruler. The material in one end of the mould is heated by a torch until it ignites and the time for burning to the opposite end of the mould is clocked. If less than 2 minutes the material is considered flammable. If the opposite end of the mould is not reached within 2 minutes the material is considered not flammable. The results of the tests conducted on dust “as received” as well as sieved with mesh 230 (<63  $\mu\text{m}$ ) are summarized in the following Table 5.0.

<b>Table 5.0 Burning Rate of Dust from Pellets</b>	
<b>Material</b>	<b>Burning Rate</b>
White Pellet Dust as received	20 mm/2 min
Bark Pellet Dust Received	22mm/2 min

Obviously the two types of dust tested are not classified as flammable as it relates to the UN MTC criteria. Classification of flammability is relevant for packaging requirement during transportation and is regulated by for example 49 Code of Federal Regulation.

#### **6. Pyrophorocity (UN Test N.4 – Class 4 Division 4.2 Substances)**

The ability of the material to ignite on contact with air is tested by exposure to air and determining the time to ignition. One or two ml of the powdery substance to be tested should be poured from about 1 m onto a non-combustible surface and it is observed whether the substance ignites during dropping or within 5 minutes of settling. This test is primarily of interest for metallic materials. No pyrophoric reaction was observed for the materials tested.

Obviously, the two types of dust tested are not classified as pyrophoric as it relates to the UN MTC criteria.

Classification of pyrophorocity is relevant for packaging requirement during transportation and is regulated by for example 49 Code of Federal Regulation.