

FIREWALL FUEL SHUT-OFF VALVES CLOSED

(EACH SWITCH PROTECTED BY RED PLASTIC GUARD)

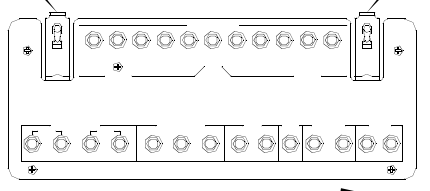

ENGINE FIRE EXTINGUISHER

(OPTIONAL EQUIPMENT)

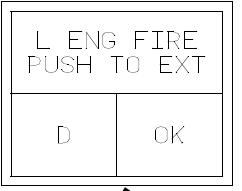

- ① FIREWALL FUEL SHUTOFF VALVES CLOSED.
- ② RAISE SAFETY-WIRED CLEAR PLASTIC COVER.
- ③ PRESS FACE OF LENS.

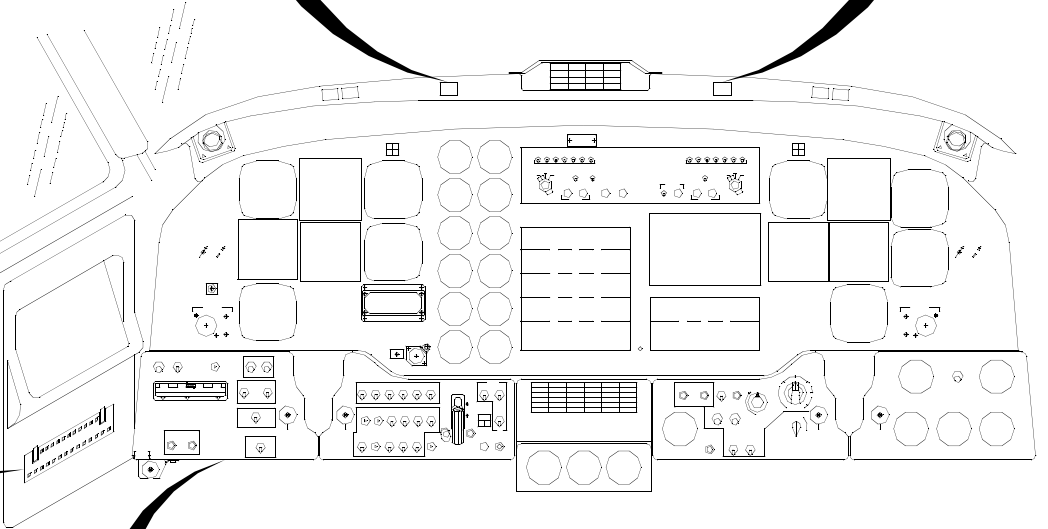
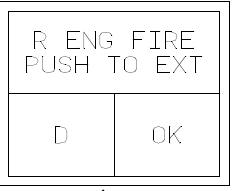

Beechcraft

**B200
[HDC]**

**CRASH , FIRE ,
AND RESCUE
INFORMATION**

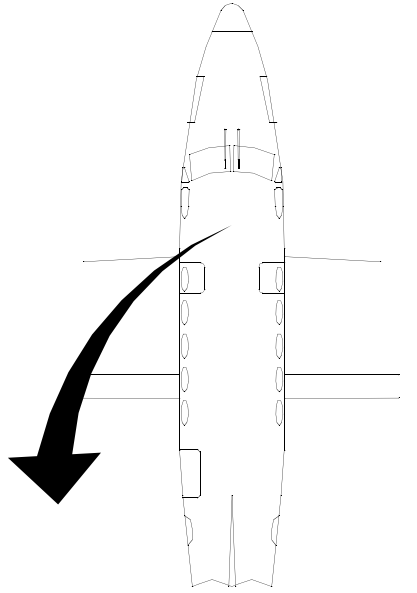

OXYGEN PUSH OFF

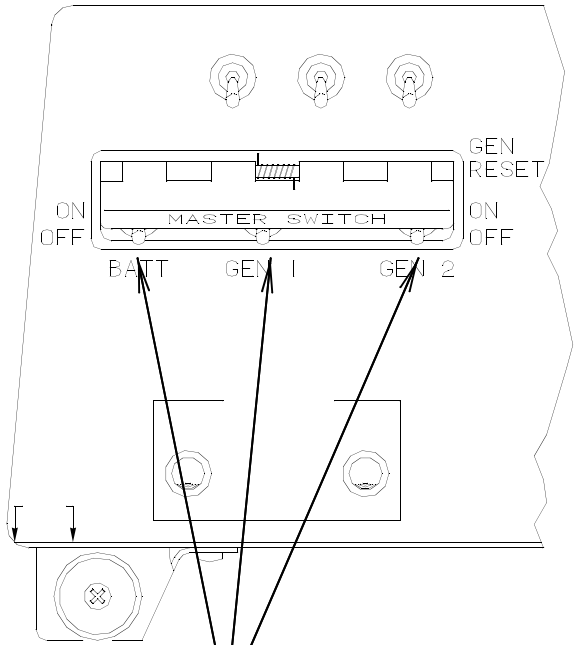

BATTERY AND GENERATOR SWITCHES OFF

(PUSH/PULL HANDLES LOCATED AFT OF OVERHEAD LIGHT CONTROL PANEL)

PULL CONDITION LEVERS FULL AFT TO SHUT OFF FUEL AT THE ENGINE.

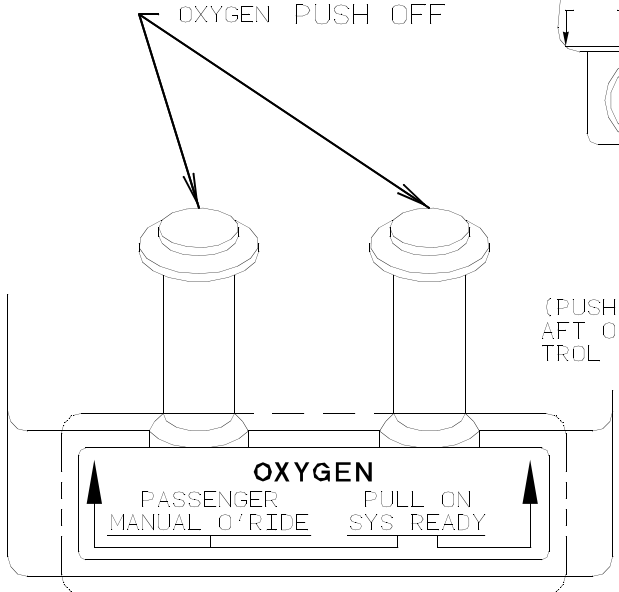
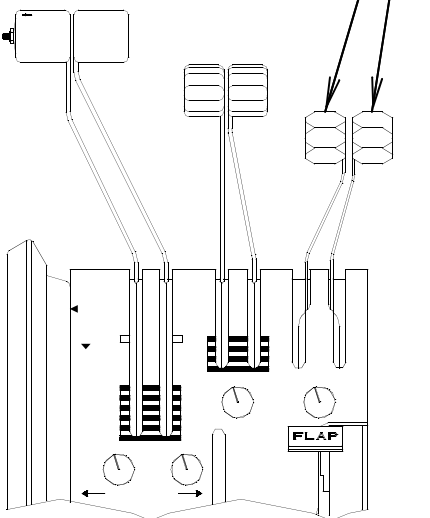

INTERNAL VIEW

PUBLISHED BY
COMMERCIAL PUBLICATIONS
BEECH AIRCRAFT CORPORATION
WICHITA, KANSAS 67201
U. S. A.

Member of GAMA
General Aviation
Manufacturers Association

Beechcraft
A Raytheon Company

THE AIRSTAIR ENTRANCE DOOR (CABIN DOOR) IS LOCATED NEAR THE AFT END OF THE PASSENGER COMPARTMENT ON THE LEFT SIDE OF THE FUSELAGE. THE DOOR IS HINGED AT THE BOTTOM AND SWINGS OUTWARD AND DOWNWARD WHEN OPENED.

TWO EMERGENCY EXIT DOORS ARE PROVIDED; ONE ON EACH SIDE OF THE FUSELAGE AT THE FORWARD END OF THE PASSENGER COMPARTMENT.

THE FUSELAGE CAN BE CUT ABOVE THE WINDOW LEVEL ANYWHERE FROM IMMEDIATELY AFT OF THE PILOTS' "D" WINDOWS TO THE AFT PRESSURE BULKHEAD (DOUBLE ROW OF RIVETS APPROXIMATELY ONE FOOT BACK OF THE AFT COMPARTMENT WINDOWS.) DASHED LINES ARE NOT PAINTED ON THE FUSELAGE.

WARNING:
OXYGEN LINES AND ELECTRICAL WIRING COULD BE ENCOUNTERED.

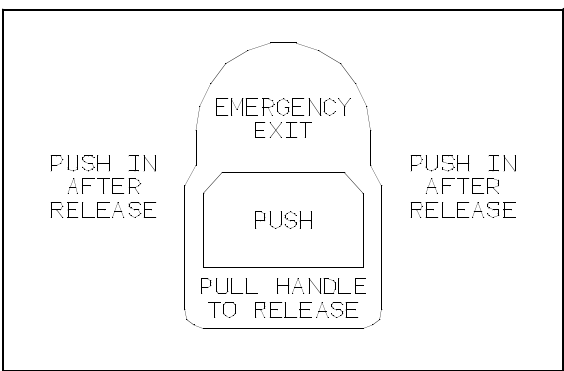
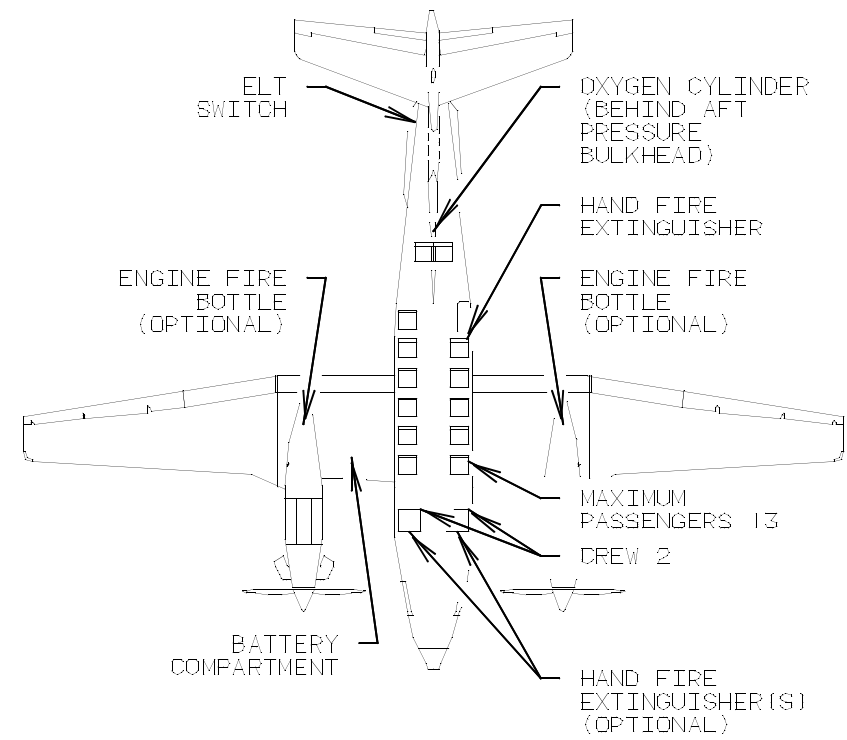
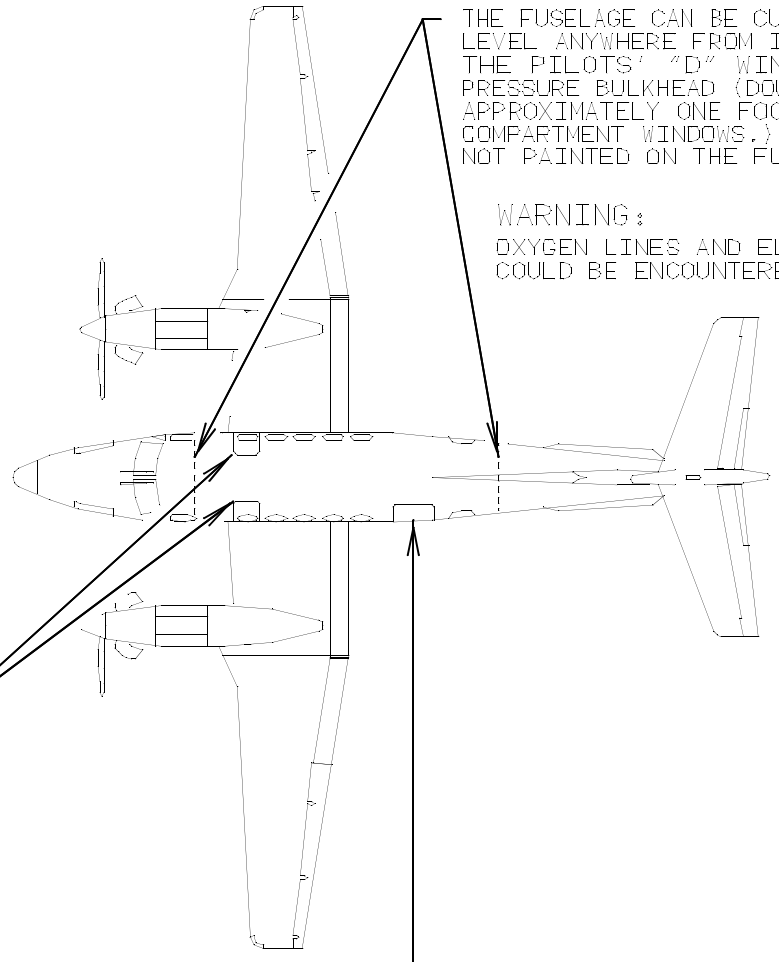

EMERGENCY EXITS

FROM THE OUTSIDE, THE DOORS ARE RELEASED WITH A FLUSH-MOUNTED PULL-OUT HANDLE. THE NON-HINGED, PLUG-TYPE DOORS REMOVE COMPLETELY FROM THE FRAME INTO THE CABIN WHEN THE LATCHES ARE RELEASED.

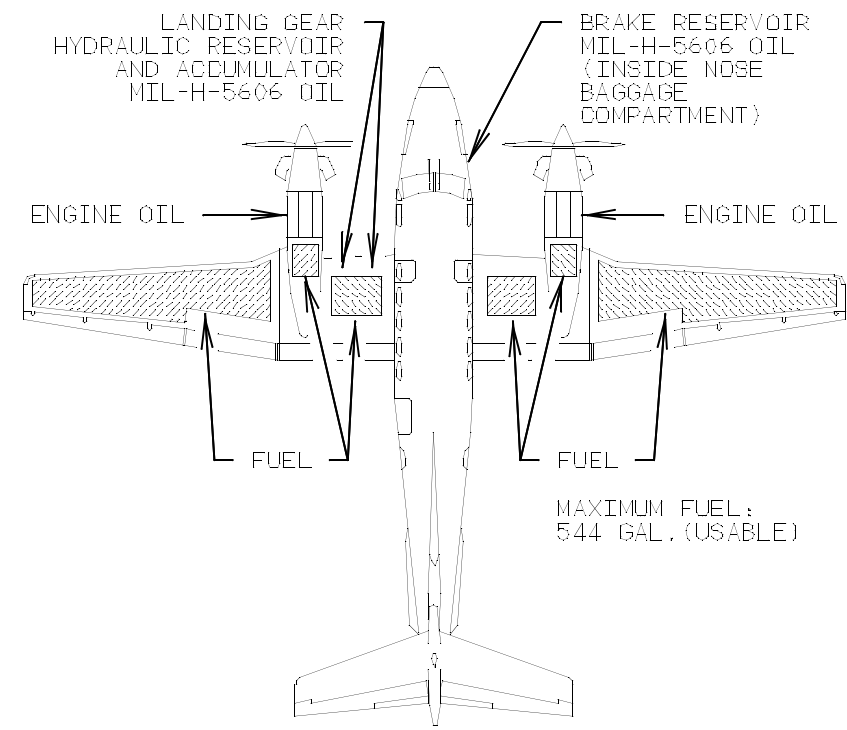
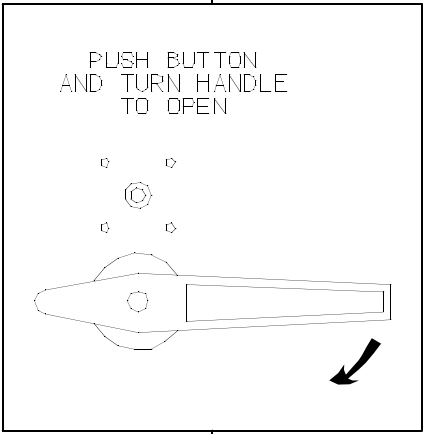

CABIN DOOR

TO OPEN THE DOOR, DEPRESS THE RELEASE BUTTON ADJACENT TO THE DOOR HANDLE AND ROTATE THE HANDLE CLOCKWISE. PULL OUT AT THE TOP OF THE DOOR, AND WITH THE AID OF THE HYDRAULIC DAMPER, LET THE DOOR DROP DOWN TO THE FULLY OPEN POSITION.

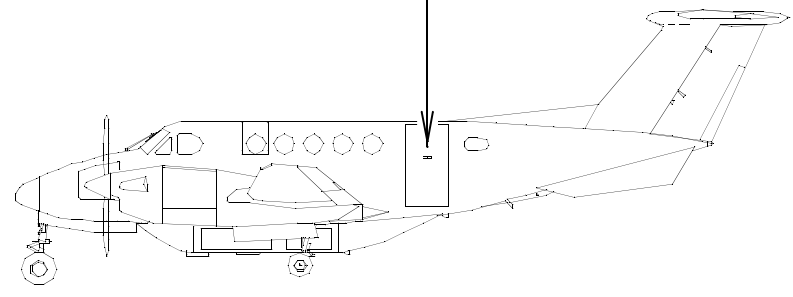

EXTERNAL VIEW